

## Installing the Switch in the Rack

### *Package Contents*

The package includes:

- 1 switch
- 1 installation kit
- 1 box containing 1 power cord Type B 6ft US 125V 10A chord
- 1 installation guide
- 1 parts list

Before you install your new switch, unpack the system and check to make sure that all the parts have been sent. Check the parts for visible damages that may have occurred during shipping.



If anything is damaged or missing, contact your customer representative immediately.



The rack mounting holes conform to the IEA-310 standard for 19-inch racks. Guarantee proper ventilation, by leaving 8cm (3") of space to the front and rear of the switch. This will ensure proper air flow through the chassis. This is crucial for maintaining good air-flow at ambient temperature. In particular, route cables such that they do not impede the air into or out of the chassis.

### *Tools and Parts*

Tools required and customer supplied parts

- Phillips Screwdrivers #1 and #2
- ESD Strap
- ESD mat
- Grounding screw
- Grounding wire sufficient to reach a valid ground

Parts Included in the Installation Kit:



Some national and/or local codes may require IT components to be bonded and externally grounded (not including the power cord ground). You must follow all national and local codes when installing this equipment.

- 2 rails
- 2 rail slides
- 6 recessed flat head screws
- 8 caged nuts with pan head screws

**Figure 1: Rail and Rail Slide**

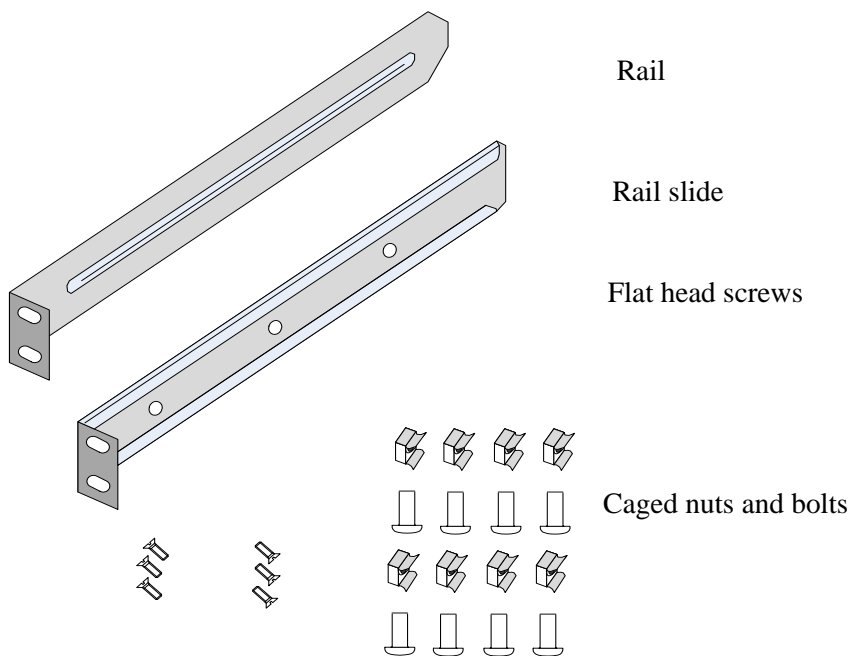

The following procedure can be done by one person.

1. Place the ESD mat on the floor where you will be working and put on the ESD strap. Make sure the ESD strap is touching your skin and that the other end is connected to a verified ground.
2. Screw the rail slides to the switch. Make sure that the ears on the slide are on the connector side of the switch. Use three flat head screws for each rail slide.

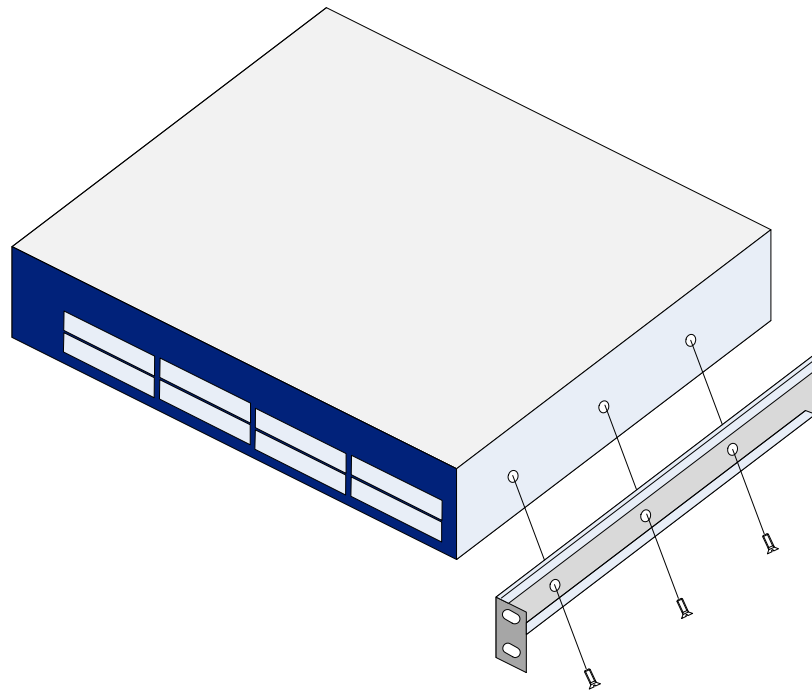
**Figure 2: Screw on the Switch Slide**

3. Put 8 caged nuts into the rack at the level you want to install the switch.
4. Screw the rails to the rack.
5. Slide the switch onto the rail slides, and screw the switch to the rack.
6. Tighten all of the screws.
7. Ground the switch.
8. Plug in the power cord.
9. You can start connecting all of the cables to the switch.

## Grounding the switch

Check to determine if your local or national electrical codes require an external ground to all IT components. If so, connect a ground wire to one of the casing screws and connect the other end to a valid ground. If you choose to not use the ground screw, make sure that the rack is properly grounded and that there is a valid ground connection between the chassis of the switch and the rack. Test the ground using an Ohm meter.



Some national and/or local codes may require IT components to be bonded and externally grounded (not including the power cord ground). You must follow all national and local codes when installing this equipment.